



AMERICAN STEEL SPAN®

vs The Competition



Our Models



P-Model *widths from 14' to 30'*

- Straight sides with pitched roof
- Perfect for a one or two car garage, backyard workshop and storage
- Economical and easy to build yourself

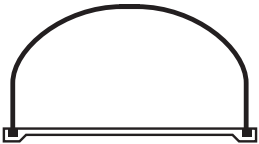

S-Model *widths from 12' to 50'*

- Straight sides with round roof
- A remarkably affordable building that is ideal for use as an airplane hanger, sand blasting and small manufacturing operation, truck, boat and RV storage and for farmers to protect livestock and equipment

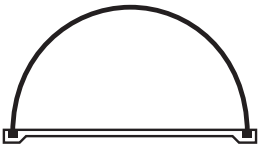

Q-Model *widths from 20' to 100'*

- A military design that allows for superior strength in widths up to 100 feet
- Withstands the worst that Mother Nature has to offer
- So versatile they can be used for everything from industrial shops and warehousing, hay, grain and livestock shelter, skating rinks and even an indoor soft-ball stadium

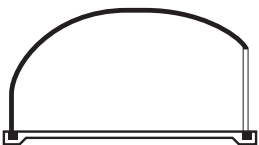

T-Model *widths from 20' to 50'*

- A unique shape offering a lean-to type application to existing structures
- Very economical when additional space is needed
- Can be erected very quickly without the need of special tools or equipment

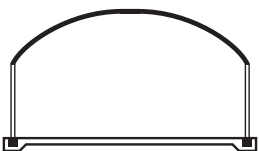

R-Model *widths from 10' to 100'*

- A durable roof system that is added to your existing walls allowing for a leak proof building with no maintenance
- Made from the highest quality US commercial steel available
- Simply bolts together for a weather tight seal



A-Model *widths from 10' to 100'*

- A durable roof system that is added to your existing walls allowing for a leak proof building with no maintenance
- Made from the highest quality US commercial steel available
- Simply bolts together for a weather tight seal

American Steel Span's Panel Overlap

- Last 9" of panel is smooth - flat, no crimps
- Fits snug together
- Saves 30-40% on erection time
- No struggle with assembly
- No caulking required for waterproofing

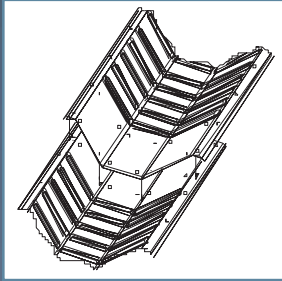

Competition's Panel Overlap

- Entire panel is crimped
- Does not fit snug together
- Difficult to assemble
- Requires 30-40% more erection time
- More alignment needed with drift pins
- Caulking is required for waterproofing – very time consuming, as each overlap must have four rows of caulking to prevent leaks

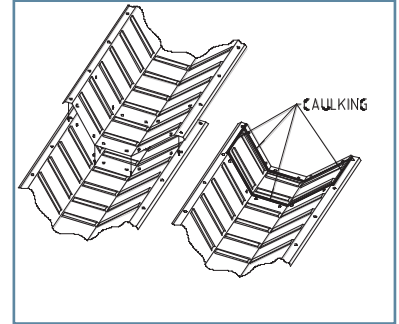

American Steel Span's Roof/Sidewall Material

- Rust-through warranty
- Minimum yield = 55 ksi
- Manufactured in accordance with ASTM International standards
- Manufactured in accordance with ASCE (American Society of Civil Engineers) building codes
- 9" overlap of panels
- Two rows of bolts
- 16 gauge beam equivalent at overlap with two rows of bolts, 0.030 overlap over a 0.030 overlap = 0.060

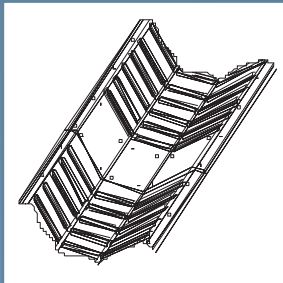

Competition's Roof/Sidewall Material

- Minimum yield = 50 ksi
- Some do not meet ASTM International standards
- Some do not meet American Society of Civil Engineers building codes
- 7" overlap of panels
- Weaker overlap with one row of bolts

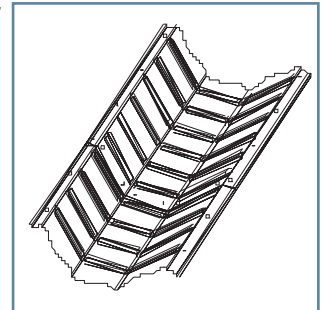

American Steel Span's Hardware

- Grade 2 bolts – 500 hour salt spray test, five times more rust resistant
- Optional - Grade 8.2 bolts – 1500 hour salt spray test
- More durable
- High strength
- Corrosion resistant

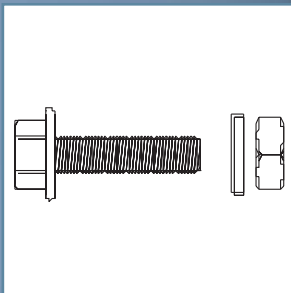

Competition's Hardware

- Some use zinc fasteners, not salt spray tested
- Less durable
- Low strength
- Not corrosion resistant

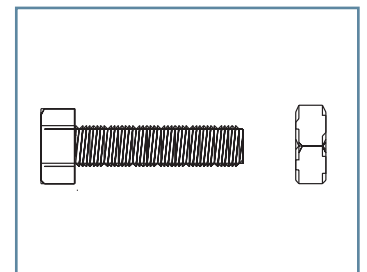

American Steel Span's Roof/Sidewall System Specification

- From a minimum of 23 gauge to 22, 20, 18, 16 and 14 gauge, depending on wind loads and snow loads
- Raw materials ordered to minimum specifications and tight tolerances
- Less tolerance variation
- AZ55 Galvalume® - 55% aluminum, 43.5% zinc, 1.5% silicone, direct warranty from steel mill
- High resistance against corrosion
- 25 year rust-through perforation limited warranty directly from the steel mill
- Studies show panel life is 40+ years
- Florida testing approval for high wind velocity, up to 150 mph. Florida approval number FL-5897

American Steel Span's Panel Crimping

- Crimps are closer together and smaller in depth
- No buckling problems
- 25% increase in strength

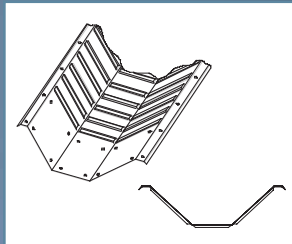

American Steel Span's Standard Endwall Panel

- AZ55 - 55% aluminum, 43.5% zinc, 1.5% silicone
- 3 1/2" corrugation depth
- 25 year rust-through perforation limited warranty directly from the steel mill
- Direct warranty from steel mill
- Florida testing approval for high wind velocity, up to 150 mph. Florida approval number FL-5898
- High resistance against corrosion
- From a minimum of 22 gauge to 20, 18, 16 and 14 gauge, depending on wind loads and snow loads

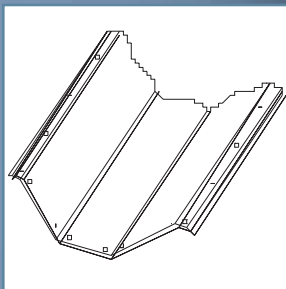

Competition's Roof/Sidewall Specification

- Material minimum less than 23 gauge
- Raw materials ordered to nominal specifications and loose tolerances
- Greater tolerance variation
- AZ50 Galvalume® - 50% aluminum, 48.5% zinc, 1.5% silicone
- Only a 20 year warranty
- Some use galvanized zinc coating – no warranty
- Low resistance against corrosion
- No Florida testing approval

Competition's Panel Crimping

- Crimps are farther apart and larger in depth
- Buckling problems
- Panels are weaker

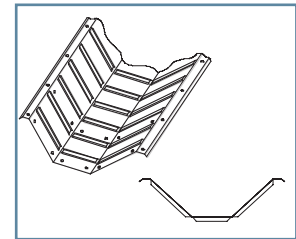

Competition's Endwall Panel

- AZ50 - 50% aluminum, 48.5% zinc, 1.5% silicone
- Only a 20 year warranty
- No Florida testing approval
- Low resistance against corrosion

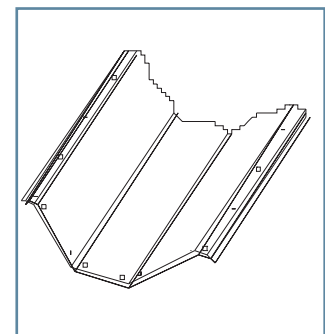

American Steel Span's Endwall Panel Color Options

- Polyester silicon or paint with endwalls
- 26 gauge, 80 ksi - galvanized C-channel framing
- Florida testing approval for high wind velocity, up to 150 mph. Florida approval number FL-3895
- Paint warranty of 25 years against chipping, blistering, cracking and peeling
- Designed to withstand the strictest of wind codes



Competition's Endwall Panel Color Options

- No colored endwalls
- No Florida testing approval
- Not designed to withstand the strictest of wind codes

American Steel Span's Roof/Sidewall Panel Color Options

- Arch panels are offered in color
- Designed to withstand the strictest of wind codes
- Florida testing approval for high wind velocity, up to 150 mph. Florida approval number FL-5897
- Paint warranty of 25 years against chipping, blistering, cracking and peeling
- Come with colored bolts



Competition's Roof/Sidewall Panel Color Options

- Arch panels are not offered in color
- Not designed to withstand the strictest of wind codes
- No Florida testing approval

American Steel Span Panel Manufacturing

MADE by AMERICAN WORKERS

- Producing the best product anywhere in the world
- Manufacturing plant is located in the United States - McKees Rocks, PA
- Comply with all U.S. state and federal laws
- Leadership has over 42 years of experience
- Largest manufacturer of arch buildings in the world

Competition's Panel Manufacturing

- Some manufacturing plants are located outside the USA - in Canada
- Warranty is subject to the guidelines of a foreign country
- Because they manufacture outside of the USA they are not subject to state and federal laws
- Leadership has less years of experience
- Warranty problems are headaches - some claims must be made in foreign countries

The American Steel Span Difference

Valued Customer,

Thank you for choosing American Steel Span as the solution to your building needs. You can be confident that the American Steel Span team of professionals will provide you with the very best products and service at the lowest competitive price in the market today. You, our valued customer, are number one on our list of priorities.

We know our business. For many years American Steel Span has provided quality pre-engineered steel building systems to commercial, industrial and agricultural customers. As an American Steel Span customer, you will receive prompt, accurate technical advice and superior customer service from our trained team of specialists. Your building package will include engineered computer aided drawings (CAD) and a comprehensive erection manual. The factory design and detailed engineering of an American Steel Span building ensures that it will last a lifetime.

The service you receive after the initial sale is the true measure of your building provider's performance. Our team of experts is dedicated to customer service and making your building project the satisfying experience you deserve. Our goal at American Steel Span is to serve you, our customer.

What We Do For You

Personalized Service

- There is no waiting. Our technicians will respond to your inquiry, discuss your needs and have your building priced to your specifications within 24 hours.
- Your experienced service representative will guide you through the entire project from purchase to completion.
- Do it yourself and save. Simple, easy erection procedures and our technical assistance will have your building up in no time.

Precision Manufacturing and Design

- State-of-the-art computerized drafting and design meet or exceed all industry standards.
- You will receive a complete building package that assembles with ease.
- Engineered permit plans, erection drawings and an easy to understand building manual are provided with every building.

Efficient Scheduling and Delivery

- Service representatives will monitor your progress to properly coordinate the arrival of your building.
- Community freight and share loading greatly reduce delivery cost.

Quality Control and Communication

- American Steel Span pledges to provide the best quality material and workmanship available in the industry.

All buildings are not created equal. Let us show you why.

Best regards,

The Service Department



Manufactured in McKees Rocks, PA 15136

www.workshopbuildings.com

1-800-715-6482